

Recommended Specification

- The Russell Dry Hip System is designed to provide a mechanically fixed, neat and attractive finish to the hip line without the use of mortar.
- It is suitable for use with all of the Russell smooth finish interlocking tile range.
- Usable on roof slopes up to a maximum of 45° pitch and where the hip eaves intersection is 90° on plan.
- The system is available in 3m packs either:
 - a) To suit flat tiles and slates
 - b) To suit profiled tiles
- Can be fitted in all dry weather conditions.
- Purpose designed block end hip tiles, to finish off the base of the hip with a pleasant appearance and secure mechanical fixing.
Available in either:
 - a) Universal Angle
 - b) Third Round

A Dry Hip Pack Comprises

Hip Tile Support Strips	4No
Hip Joint Gasket	7No
100mm S/S Nails	7No
115mm S/S Nails	7No
Hip Batten Spacers	7No
Hip Roll	1No
Hip Batten Connector	7No

Hip end tiles are available to order separately.

Dry Hip System

For Flat Tiles

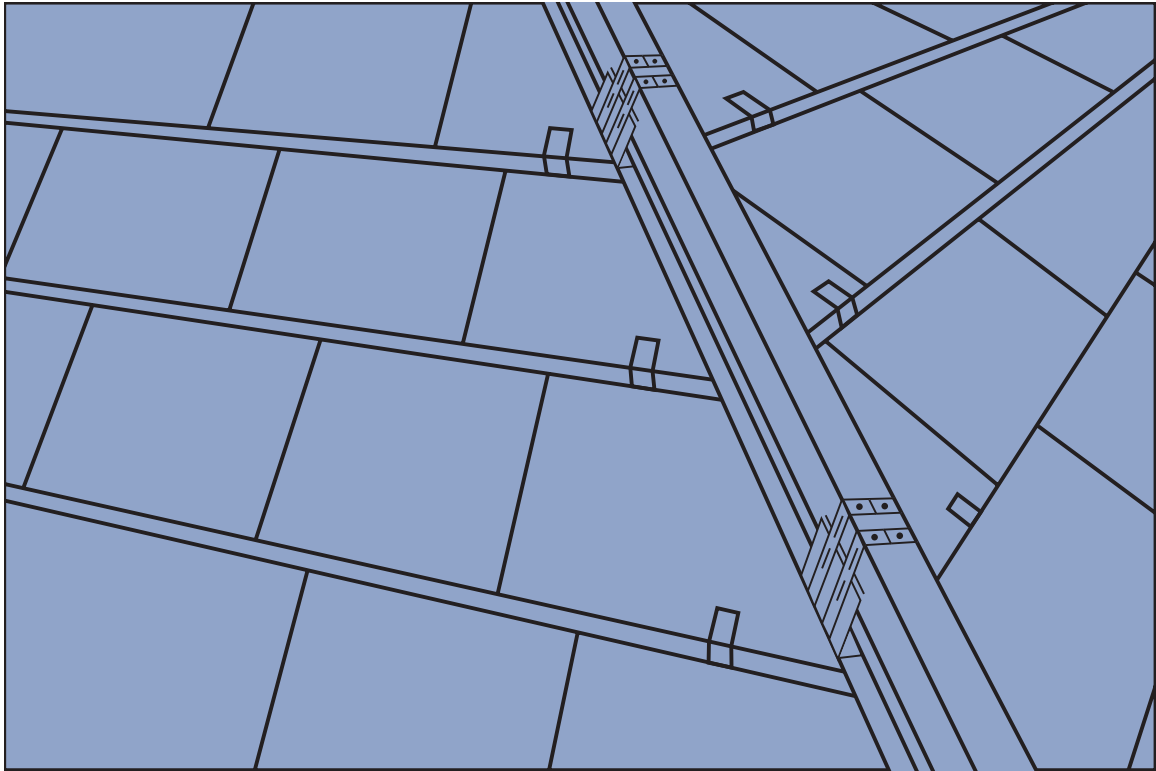

The components

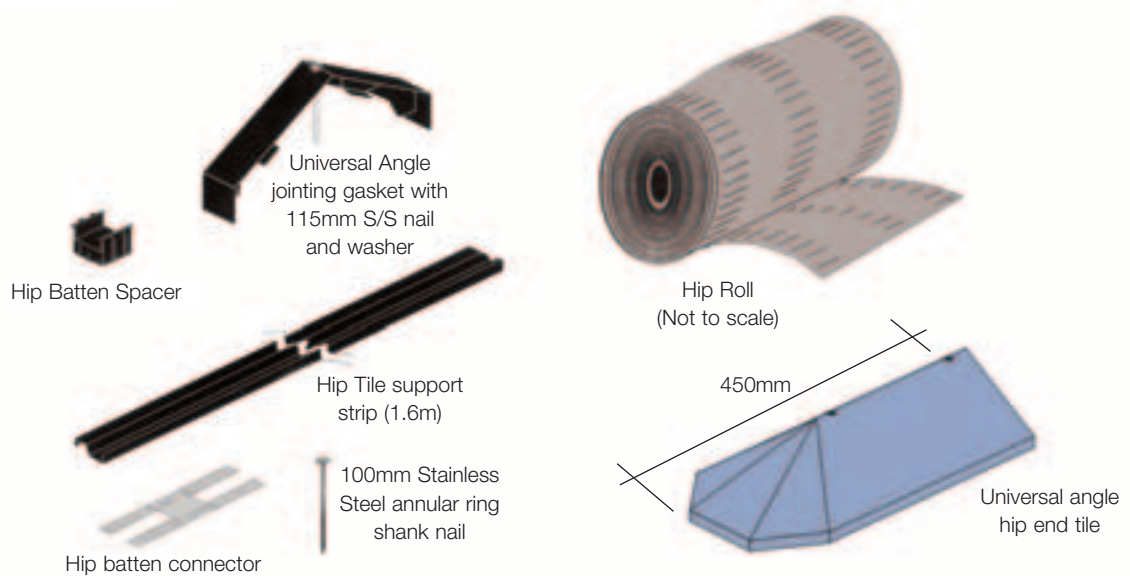

Dry Hip System

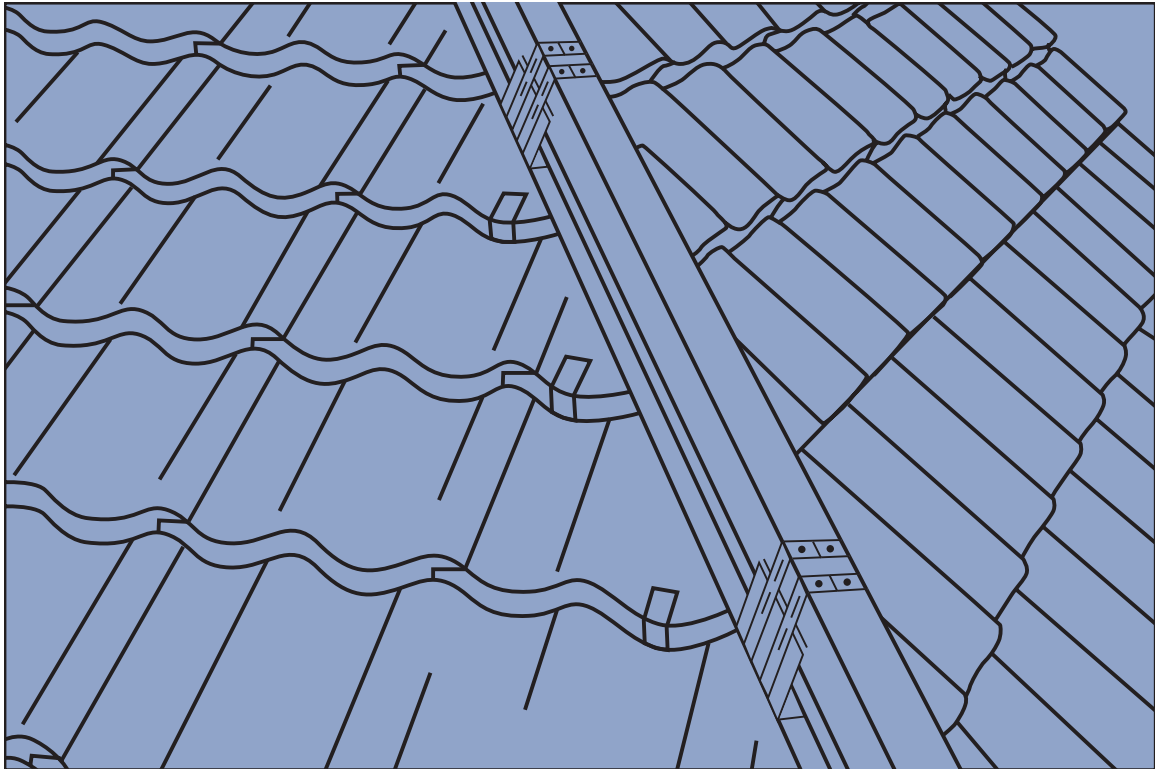

The componenets

